

CALIBRADOR DIAL

Serie 101

Herramienta



Dibujo Técnico

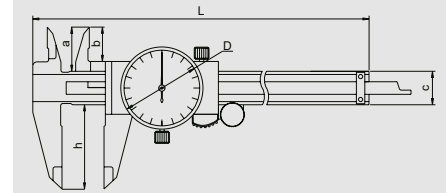

CARACTERÍSTICAS									PRECIO SIN IVA
Código	Rango	Exactitud	a	b	c	h	D	L	
101-006-21	0-150mm	0.03mm	21	16.5	16	40	Ø39	233	\$45,00
101-008-21	0-200mm	0.03mm	24	19	16	50	Ø39	288	\$57,00
101-012-21	0-300mm	0.04mm	30	25	20	54	Ø44	390	\$85,00

CALIBRADOR DIGITAL

Serie 111

Herramienta



Dibujo Técnico

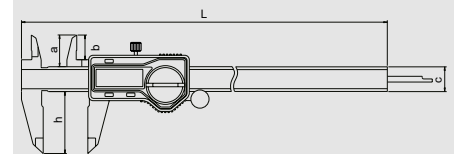

CARACTERÍSTICAS								PRECIO SIN IVA
Código	Rango	Exactitud	a	b	c	D	L	
111-006-12	0-150mm/0-6"	0.03mm	21	16	16	40	236	\$34,00
111-008-12	0-200mm/0-8"	0.03mm	24	19	16	50	286	\$53,00
111-012-12	0-300mm/0-12"	0.03mm	25	20.5	16	60	400	\$86,00

CALIBRADOR DIGITAL RESISTENTE A FLUIDOS

Serie 112

Herramienta



Dibujo Técnico

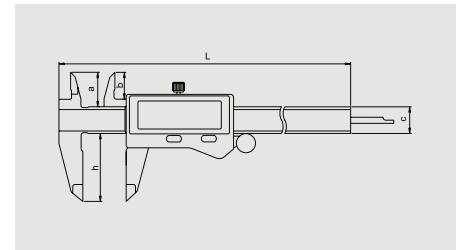

CARACTERÍSTICAS								PRECIO SIN IVA
Código	Rango	Exactitud	a	b	c	h	L	
112-008-13	0-200mm/0-8"	0.03mm	24	19	16	50	286	\$110,00

CALIBRADOR DIGITAL PARA INTERIORES

Serie 159

Herramienta



Dibujo Técnico

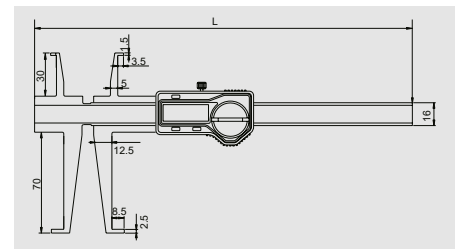

CARACTERÍSTICAS					PRECIO SIN IVA
Código	Rango del maxilar superior	Rango del maxila inferior	Exactitud	L	
159-008-11	9-200mm	15-200mm	0.06mm	3100	\$195,00

CALIBRADOR DE PROFUNDIDAD DIGITAL

Serie 176

Herramienta



Dibujo Técnico

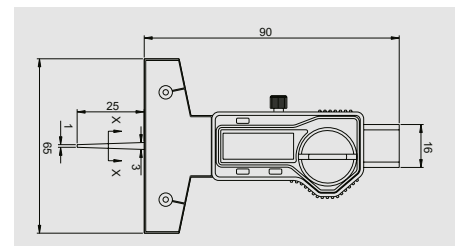

CARACTERÍSTICAS			PRECIO SIN IVA
Código	Rango	Exactitud	
176-001-11	0-25mm/0-1"	0.03mm	\$52,00

CALIBRADORES

CALIBRADOR PIE DE REY

Serie 129

Herramienta



Dibujo Técnico

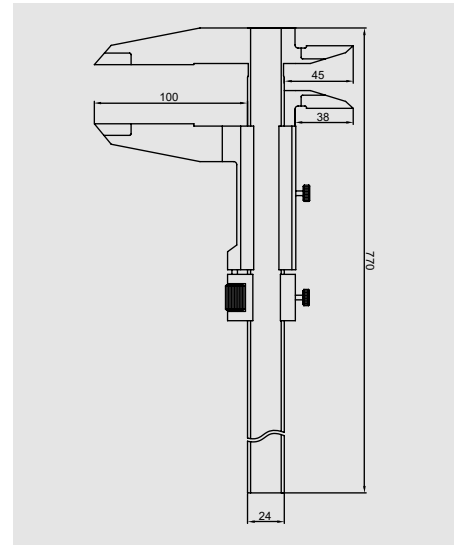

CARACTERÍSTICAS									PRECIO SIN IVA
Código	Rango	Exactitud	a	b	c	h	W	L	
129-020-51	0-500mm/0-20"	0.07mm	18	45	24	100	20	670	\$283,00

CALIBRADOR PIE DE REY

Serie 146

Herramienta



Dibujo Técnico

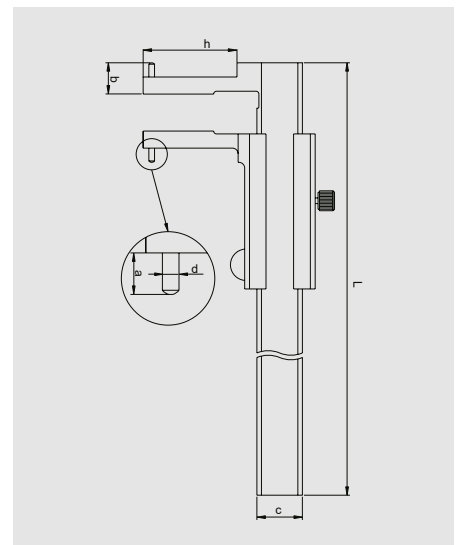

CARACTERÍSTICAS									PRECIO SIN IVA
Código	Rango	Exactitud	a	b	c	d	D	L	
146-012-11	50-300mm	0.06mm	8	25	17	Ø3	80	410	\$211,00

CALIBRADOR PIE DE REY

Serie 120

Herramienta



Dibujo Técnico

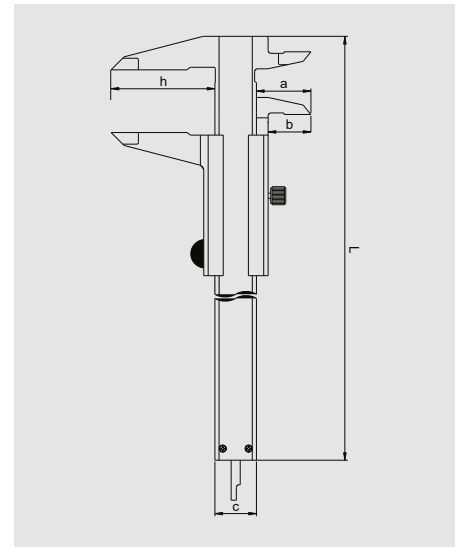

CARACTERÍSTICAS								PRECIO SIN IVA
Código	Rango	Exactitud	a	b	c	h	L	
120-012-12	0-300mm/0-12"	0.03mm	27.5	22	20	64	414	\$67,00
120-006-14	0-150mm/0-6"	0.05mm	20.5	15.5	16	40	235	\$26,00
120-006-14	0-150mm/0-6"	0.05mm	20.5	15.5	16	40	235	\$37,00
120-012-14	0-300mm/0-12"	0.05mm	27.5	22	20	64	414	\$67,00

CALIBRADORES

CALIBRADOR DE ALTURA DE RELOJ

Serie 185

Herramienta



Dibujo Técnico

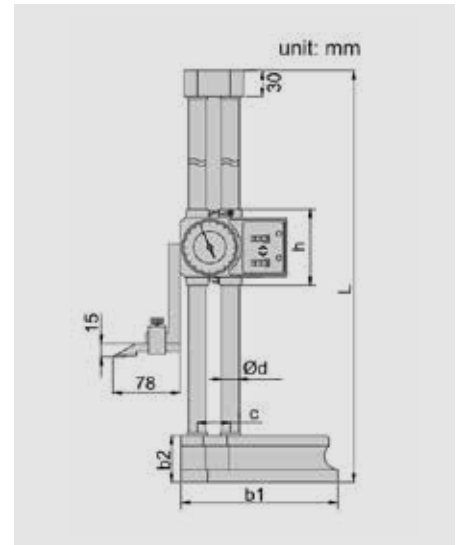

CARACTERÍSTICAS									PRECIO SIN IVA
Código	Rango	Exactitud	b1	b2	c	Ød	h	L	
186-012-10	0-300mm/0-12"	0.04mm	135	43	33	15	84	475	\$274,00

CALIBRADOR DE ALTURA

Serie 186

Herramienta



Dibujo Técnico

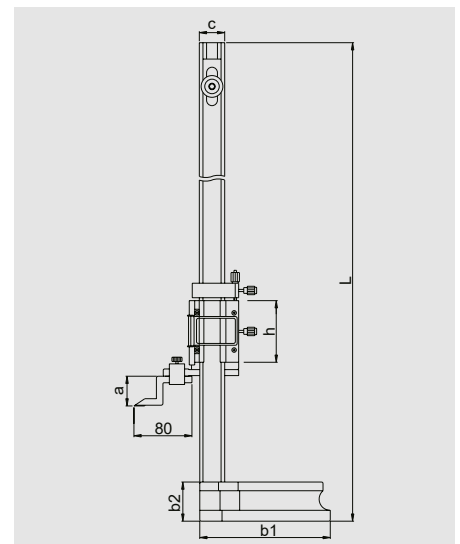

CARACTERÍSTICAS									PRECIO SIN IVA
Código	Rango	Exactitud	a	b1	b2	c	h	L	
186-012-11	0-300mm/0-12"	0.04mm	30	135	43	28	75	545	\$198,00

CALIBRADOR DE ESPESORES

Serie 911

Herramienta



Dibujo Técnico

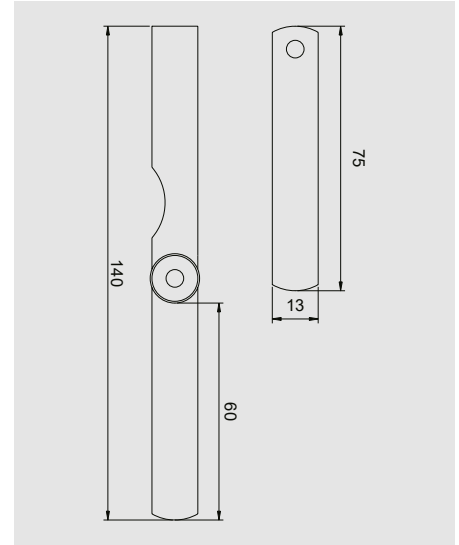

CARACTERÍSTICAS				PRECIO SIN IVA
Código	Rango	Cantidad	Grosor de las hojas (mm)	
911-100-25	0.04 - 1.00mm	25	0.04, 0.05, 0.06, 0.07, 0.08, 0.09, 0.10, 0.15, 0.20, 0.25, 0.30, 0.35, 0.40, 0.45, 0.50, 0.55, 0.60, 0.65, 0.70, 0.75, 0.80, 0.85, 0.90, 0.95, 1.00	\$5,00

CALIBRADOR DE ESPESORES

Serie 912

Herramienta



Dibujo Técnico

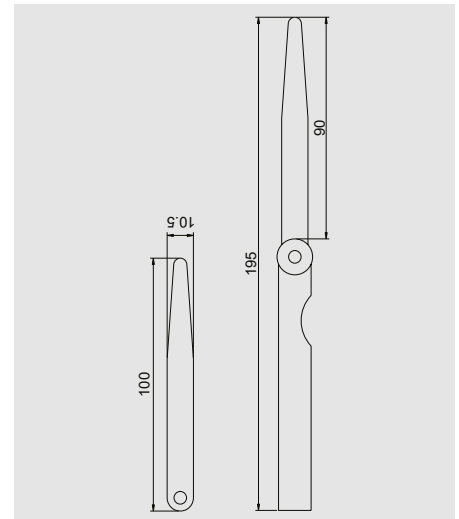

CARACTERÍSTICAS				PRECIO SIN IVA
Código	Rango	Cantidad	Grosor de las hojas (mm)	
912-100-32	0.03 - 1.00mm	32	0.03, 0.04, 0.05, 0.06, 0.07, 0.08, 0.09, 0.10, 0.13, 0.15, 0.18, 0.20, 0.23, 0.25, 0.28, 0.30, 0.33, 0.35, 0.38, 0.40, 0.45, 0.50, 0.55, 0.60, 0.63, 0.65, 0.70, 0.75, 0.80, 0.85, 0.90, 1.00	\$7,00

CALIBRADOR DE ROSCA

Serie 922/924/925

Herramienta



Dibujo Técnico

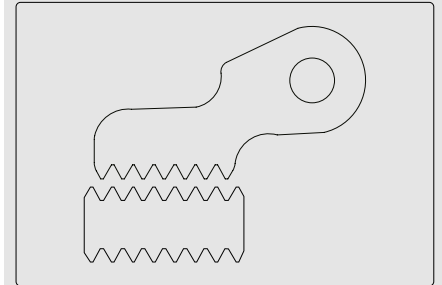
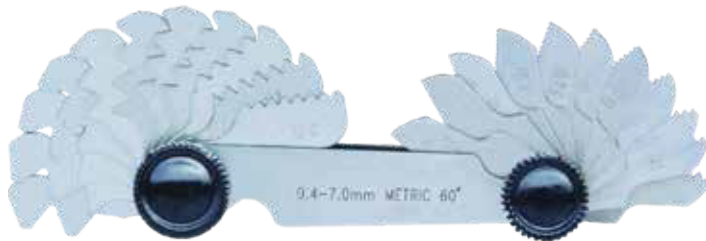

CARACTERÍSTICAS				PRECIO SIN IVA
Código	Rango	Cantidad	Grosor de las hojas	
922-007-24	0.25 - 7.0mm	24	0.25, 0.3, 0.35, 0.4, 0.5, 0.7, 0.75, 0.8, 0.9, 1, 1.25, 1.5, 1.75, 2, 2.5, 3, 3.5, 4, 4.5, 5, 5.5, 6, 6.5, 7mm	\$9,75
924-062-28	4 - 62TPI	28	4, 4-1/2, 5, 6, 7, 8, 9, 10, 11, 12, 13, 14, 16, 18, 19, 20, 22, 24, 25, 26, 28, 30, 32, 36, 40, 48, 60, 62TP	\$10,00
925-062-52	0.25 - 6.0mm and 4 - 62TPI	52	pitch of 922-006-24 and 924-062-28	\$11,00

CALIBRADORES DE ESPESORES

GONIOMETRO

Serie 811

Herramienta



Dibujo Técnico

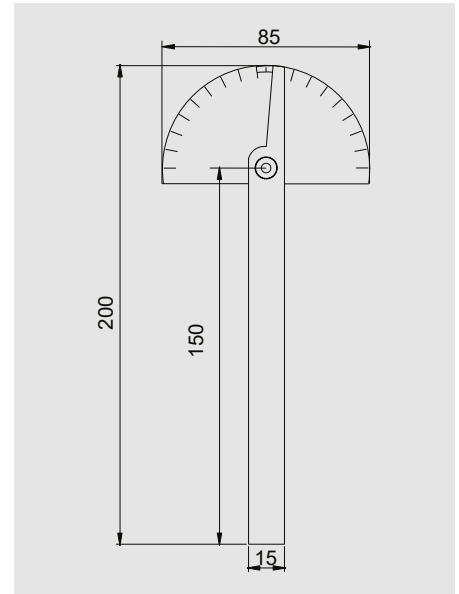

CARACTERÍSTICAS				PRECIO SIN IVA
Código	Tamaño	Rango	Exactitud	
811-180-01	85x150mm	0-180°	±0.3°	\$20,00

SET ESCUADRA COMBINADAS

Serie 817

Herramienta



Dibujo Técnico

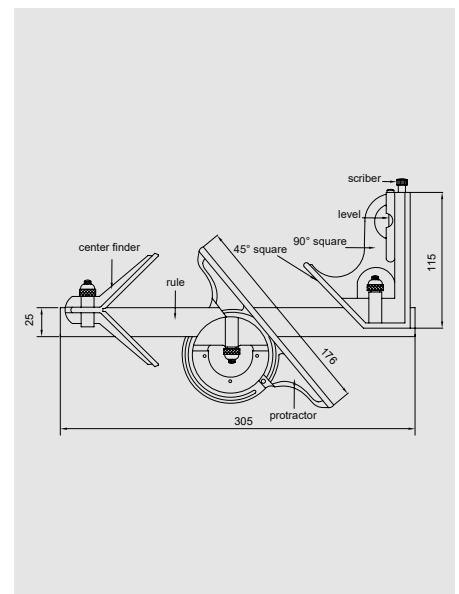

CARACTERÍSTICAS			PRECIO SIN IVA
Código	Rango de Medición	Precisión	
817-180-02	0-180°	7	\$112,00

GONIOMETRO DIGITAL

Serie 821

Herramienta



Dibujo Técnico

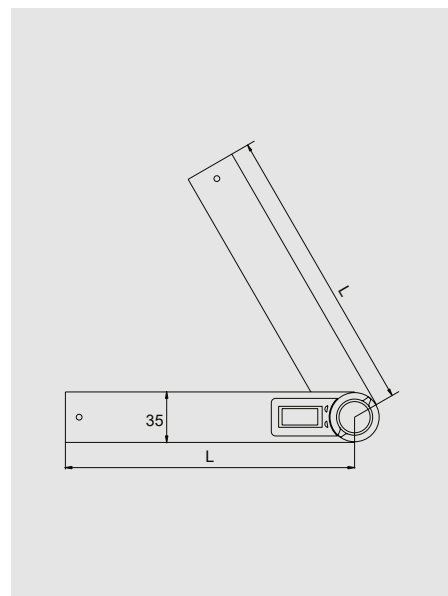

CARACTERÍSTICAS				PRECIO SIN IVA
Código	Tamaño (L)	Rango	Exactitud	
821-008-01	200mm	0-360°	0.3°	\$36,00
821-012-01	300mm	0-360°	0.3°	\$36,00

REGLAS

Serie 991

Herramienta



Dibujo Técnico

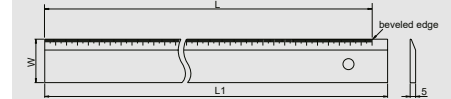

CARACTERÍSTICAS					PRECIO SIN IVA
Código	Rango (L)	Rectitud	W	L1	
991-012-01	300mm	0.02mm	40mm	320mm	\$45,00
991-020-01	500mm	0.03mm	40mm	520mm	\$86,00
991-040-01	1000mm	0.04mm	50mm	1020mm	\$147,00

REGLAS

Serie 991

Herramienta



Dibujo Técnico

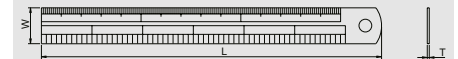

CARACTERÍSTICAS						PRECIO SIN IVA
Código	Rango	Exactitud	T	L	W	
990-020-11	500mm/20"	0.14mm	1mm	530mm	30mm	4,50
990-040-1	1000mm/40"	0.24mm	1.5mm	1040mm	32mm	10,00

ESCUADRA CON ESPALDON

Serie 842

Herramienta



Dibujo Técnico

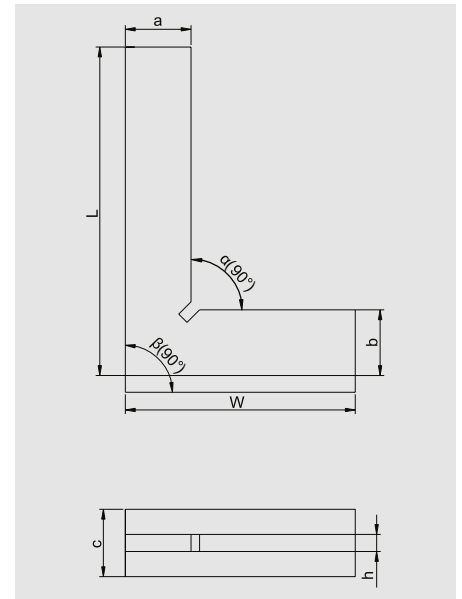

CARACTERÍSTICAS								PRECIO SIN IVA
Código	Tamaño(LxA)	Cuadratura(α)	Cuadratura(β)	a	b	c	h	
842-006-10	150x100mm	7 μ m	7 μ m	30	30	30	6	\$66.00
842-008-10	200x130mm	8 μ m	8 μ m	34	34	30	7	\$88.50

RELOJ COMPARADOR DE PRECISIÓN

Serie 222/223

Herramienta



Dibujo Técnico

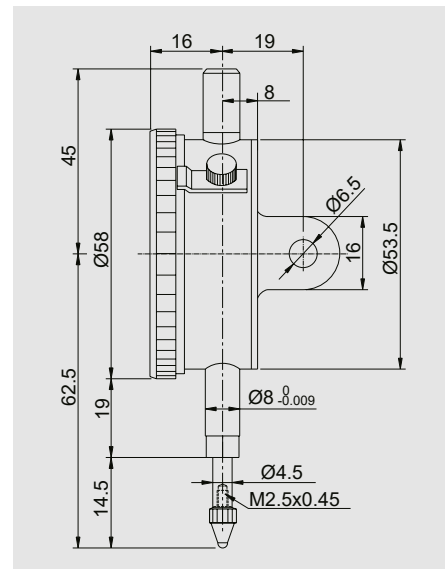

CARACTERÍSTICAS

Código	Rango	Atrás	Escala	Exactitud	Histéresis	PRECIO SIN IVA
222-001-01	1mm	lug	0-100-0	5µm	2µm	\$67.00
223-010-11	10mm	lug	0-100	20µm	3µm	\$24.00

PUNTO PARA RELOJ COMPARADOR

Serie 842

Herramienta



Dibujo Técnico

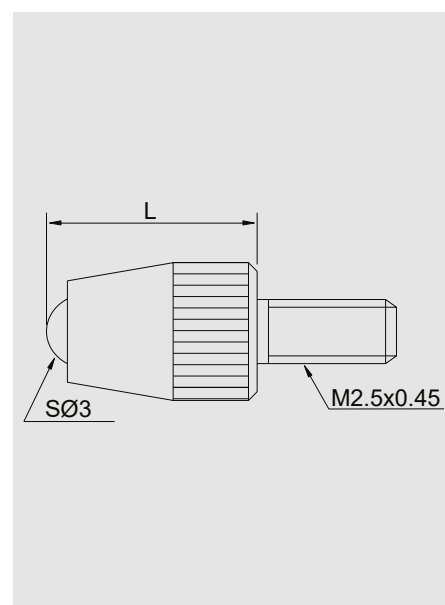

CARACTERÍSTICAS

Código	Material	L(mm)	PRECIO SIN IVA
270-001-05	Carburo	14	\$14.70

RELOJES



RELOJ COMPARADOR PATA LARGA

Serie 842

Herramienta



Dibujo Técnico

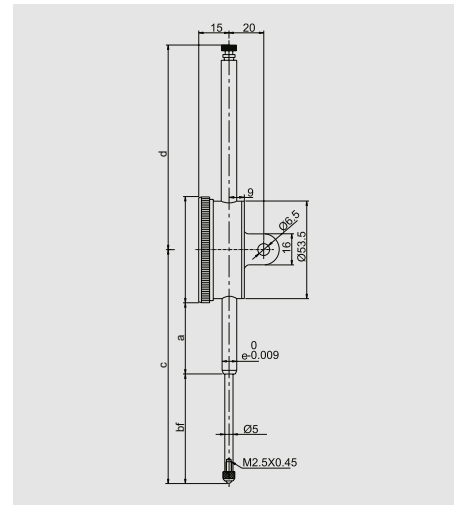

CARACTERÍSTICAS											
Código	Rango	Exactitud	Histéresis	Escala	a	b	c	d	e	f	PRECIO SIN IVA
229-050-21	50mm	40µm	8µm	0-100	40mm	58mm	127mm	108mm	Ø8mm	Ø58mm	\$99.00
229-100-21	100mm	50µm	9µm	0-100	60mm	108mm	207mm	168mm	Ø10mm	Ø78mm	\$252.00

RELOJES



RELOJ PALPADOR

Serie 261

Herramienta



Dibujo Técnico

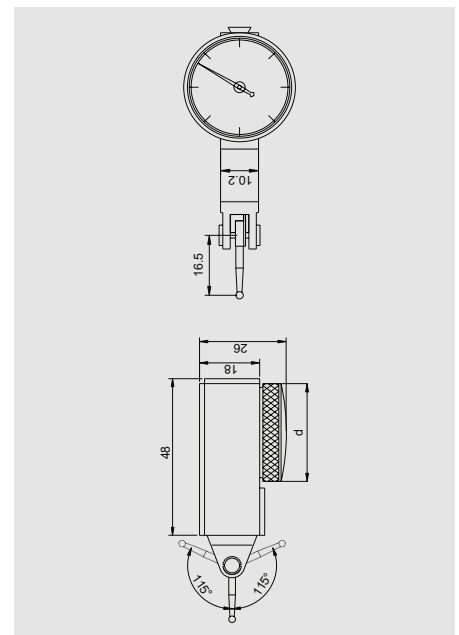

CARACTERÍSTICAS								PRECIO SIN IVA
Código	Rango	Bisel(d)	Graduación	Estilo	Exactitud	Histéresis	Escala	PRECIO SIN IVA
261-008-11	0.8mm	Ø30mm	0.01mm	Carburo	13µm	3µm	0-40-0	\$50.00

RELOJ PALPADOR CON PATAS LARGAS

Serie 263

Herramienta



Dibujo Técnico

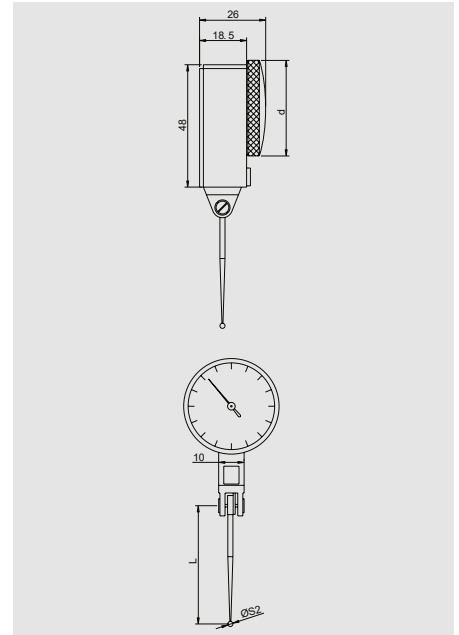

CARACTERÍSTICAS								L	PRECIO SIN IVA
Código	Rango	Bisel(d)	Graduación	Estilo	Exactitud	Histéresis	Escala		
263-008-11L	0.8mm	Ø37.5mm	0.01mm	Rubí	13µm	9µm	0-40-0	46.4	\$95.00

PUNTA REPUESTO RELOJ PALPADOR

Serie 260

Herramienta



Dibujo Técnico

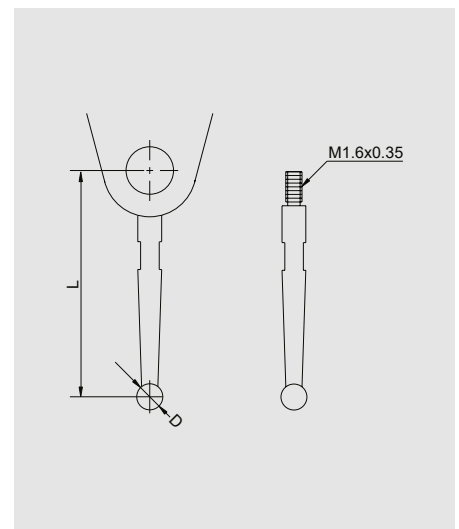

CARACTERÍSTICAS					PRECIO SIN IVA
Código	Para productos	Punta del material	D(mm)	L(mm)	
260-010-01	261-008-11 261-008-12 266-016-11 264-008-11 265-008-11	Rubí	SØ2	16.5	\$7.00

SOPORTE INDICADOR CON BASE DE GRANITO

Serie 289

Herramienta



Dibujo Técnico

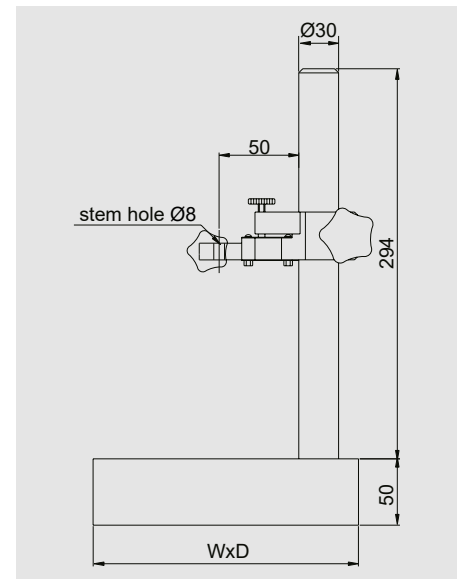

CARACTERÍSTICAS				PRECIO SIN IVA
Código	Agujero del vástago	Planitud de la base	Tamaño de la base (WxD)	
289-012-01	Ø8mm	3.2µm	300x200mm	\$630.00

RELOJ DIGITAL

Serie 214

Herramienta



Dibujo Técnico

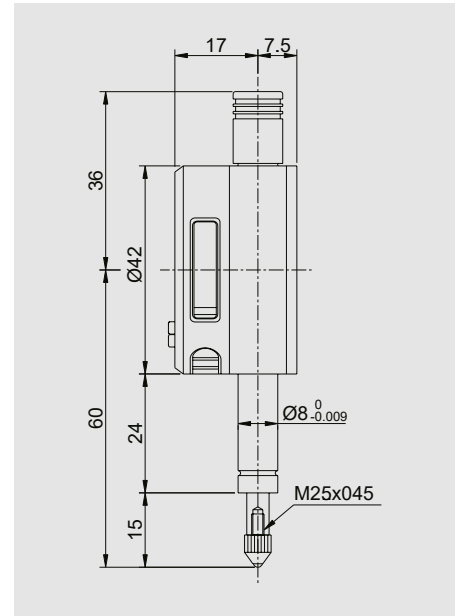

CARACTERÍSTICAS				PRECIO SIN IVA
Código	Rango	Exactitud	Histéresis	
214-005-02	5mm/0.2"	5µm	3µm	\$164.00

RELOJ DIGITAL

Serie 211

Herramienta



Dibujo Técnico

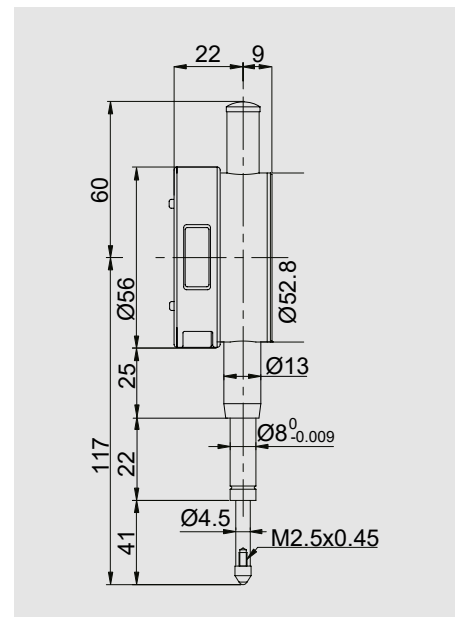

CARACTERÍSTICAS				PRECIO SIN IVA
Código	Rango	Exactitud	Histéresis	
211-025-03	25.4mm/1"	5µm	3µm	\$199.00

INDICADOR DE PROFUNDIDAD DIAL

Serie 292

Herramienta



Dibujo Técnico

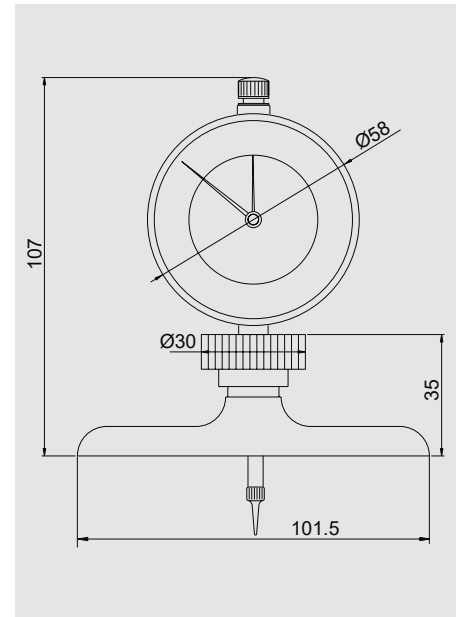

CARACTERÍSTICAS			PRECIO SIN IVA
Código	Rango	Base	
292-300-12	0-300mm	101.5x17mm	\$108.00



CALIBRADOR AGUJEROS PEQUEÑOS

CALIBRADOR DE PRECISION PARA AGUJEROS PEQUEÑOS

Serie 251

Herramienta



Dibujo Técnico

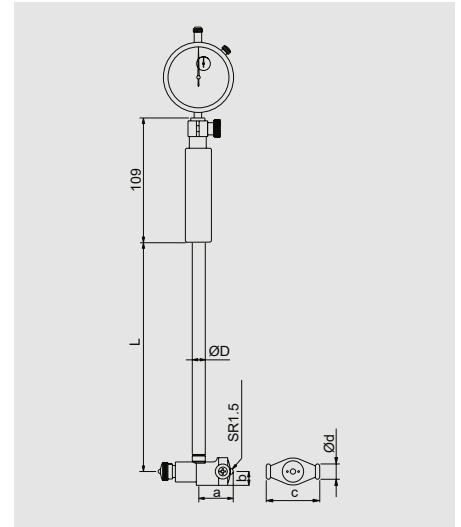

CARACTERÍSTICAS														PRECIO SIN IVA
Código	Rango	Indicador digital	Sugerencias	Empaquetadura	Exactitud	Repetibilidad	a	b	c	Ød	ØD	e	L	
251-160-11	50-160mm	Range:10mm graduation: 0.01mm	12pcs	4pcs	0.018mm	3µm	26	9	35	13	12.8	SR2	141	\$83.00
251-018-01	10-18mm	Range:1mm graduation: 0.01mm	9pcs	2pcs	0.005mm	2µm	5.6	7.8	/	/	6	SR1	105	\$228.00
251-035-01	18-35mm		9pcs	2pcs	0.006mm	2µm	12.2	6.4	/	12.7	9	SR1	141	\$205.00
251-160-01	50-160mm		12pcs	4pcs	0.007mm	2µm	26	9	35	13	12.8	SR2	141	\$190.00

CALIBRADOR PRECISION PARA AGUJEROS PEQUEÑOS DIGITAL

Serie 251

Herramienta



Dibujo Técnico

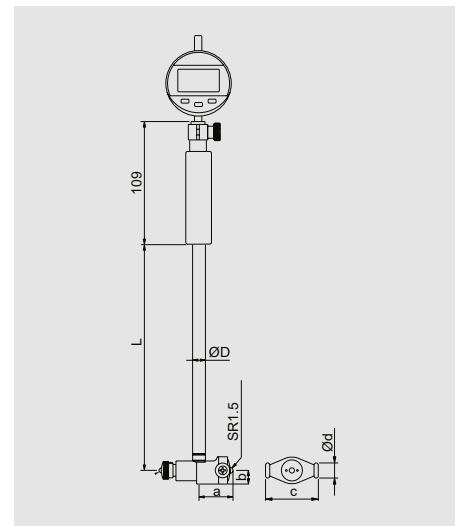

CARACTERÍSTICAS														PRECIO SIN IVA
Código	Rango	Indicador digital	Sugerencias	Empaquetadura	Exactitud	Repetibilidad	a	b	c	Ød	ØD	e	L	
241-160-11	50-160mm	Range:12.7mm graduation: 0.002mm	12pcs	4pcs	0.018mm	3µm	26	9	35	13	12.8	SR2	141	\$211.00

MICROMETROS EXTERIORES

Serie 251

Herramienta



Dibujo Técnico

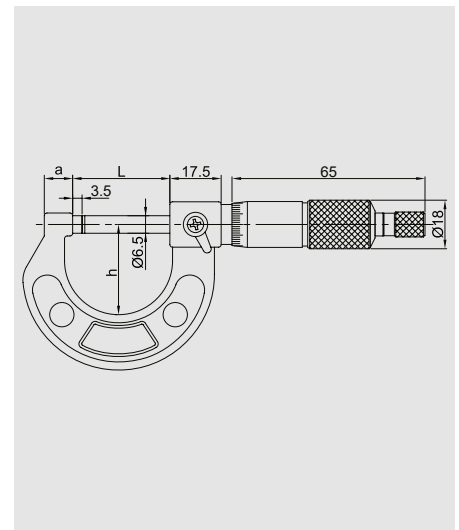

CARACTERÍSTICAS

Código	Rango	Exactitud	a	h	L	Establecimiento de normas	PRECIO SIN IVA
321-001-01	0-25mm	4µm	9	29	32	-	\$24.00
321-002-01	25-50mm	4µm	9	39	58	25mm	\$28.00
321-003-01	50-75mm	5µm	10	53	83	50mm	\$30.00
321-004-01	75-100mm	5µm	10	65	109	75mm	\$31.00
321-005-01	100-125mm	6µm	11.5	76	133	100mm	\$42.50
321-006-01	125-150mm	6µm	11.5	88	159	125mm	\$48.00
321-007-01	150-175mm	7µm	11.5	101	185	150mm	\$56.00
321-008-01	175-200mm	7µm	11.5	114	210	175mm	\$62.00

MICROMETROS EXTERIORES

MICRÓMETRO DE EXTERIORES DIGITAL

Serie 251

Herramienta



Dibujo Técnico

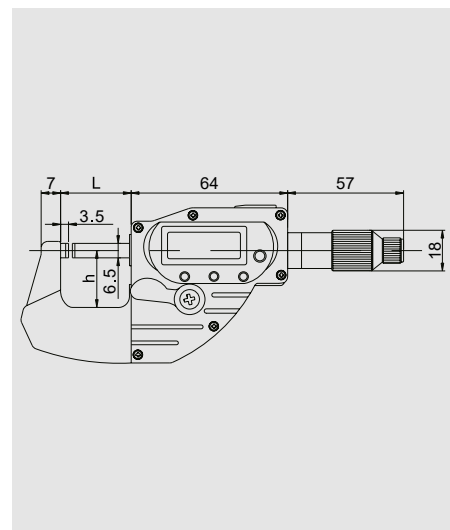

CARACTERÍSTICAS						PRECIO SIN IVA
Código	Rango	Exactitud	h	L	Establecimiento de normas	
314-001-02	0-25mm/0-1"	3μm	25	31	-	\$151.00
314-002-02	25-50mm/1-2"	3μm	32	57	25mm	\$164.00
314-003-02	50-75mm/2-3"	4μm	44.5	82	50mm	\$187.00
314-004-02	75-100mm/3-4"	4μm	57	107	75mm	\$209.00



MICROMETROS DE EXTERIORES PULGADAS

Serie 324

Herramienta



Dibujo Técnico

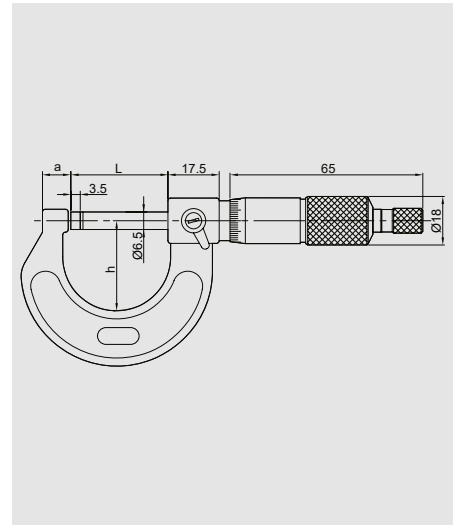

CARACTERÍSTICAS							PRECIO SIN IVA
Código	Rango	Exactitud	a	h	L	Establecimiento de normas	
324-001-01	0-1"	0.00016"	9	29	32	-	\$30.00
324-002-01	1-2"	0.00016"	14	39	58	1"	\$38.00
324-003-01	2-3"	0.0002"	15	53	83	2"	\$39.00
324-004-01	3-4"	0.0002"	15	65	109	3"	\$41.00
324-005-01	4-5"	0.00024"	16.5	76	133	4"	\$52.00
324-006-01	5-6"	0.00024"	16.5	88	159	5"	\$54.00

MICROMETROS DE EXTERIORES

JGO. DE MICROMETROS DE EXTERIORES 6 PZAS

Serie 321 / 324

Herramienta



JUEGO DE MICROMETROS

CARACTERÍSTICAS					PRECIO SIN IVA
Código	Rango	Total QTY	Micrómetros incluidos	Fijación de normas	
321-006-06	0-150mm	6pcs	0-25, 25-50, 50-75, 75-100, 100-125, 125-150mm	100-125, 125-150mm	\$205.00
321-012-06	150-300mm	6pcs	150-175, 175-200, 200-225, 225-250, 250-275, 275-300mm	150, 175, 200, 225, 250, 275mm	\$442.00
324-006-06	0-6"	6pcs	0-1", 1-2", 2-3", 3-4", 4-5", 5-6"	1", 2", 3", 4", 5"	\$255.00

MICROMETROS DE INTERIORES

Serie 351

Herramienta



Dibujo Técnico

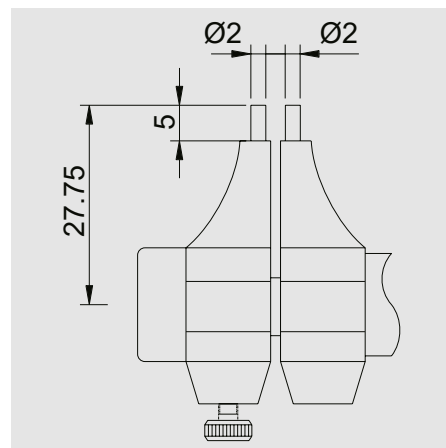

CARACTERÍSTICAS					PRECIO SIN IVA
Código	Rango	Exactitud	Tipo	Anillo de fijación	
351-001-01	5-30mm	5µm	A	5mm	72.00
351-002-01	25-50mm	6µm	B	25mm	78.00
351-003-01	50-75mm	7µm	C	optional	100.00
351-004-01	75-100mm	8µm	C	optional	106.00
351-005-01	100-125mm	9µm	C	optional	125.00

MICRÓMETRO DE INTERIORES TUBULAR

Serie 352

Herramienta



Dibujo Técnico

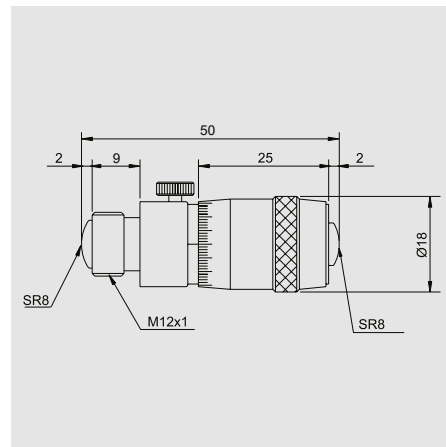

CARACTERÍSTICAS			PRECIO SIN IVA
Código	Rango	Varillas de prolongación (mm)	
352-006-01	50-150mm	13, 25, 50	\$114.00
352-012-01	50-300mm	13, 25, 50(2pcs), 100	\$153.00

MICROMETRO DE PROFUNDIDAD

Serie 391

Herramienta



Dibujo Técnico

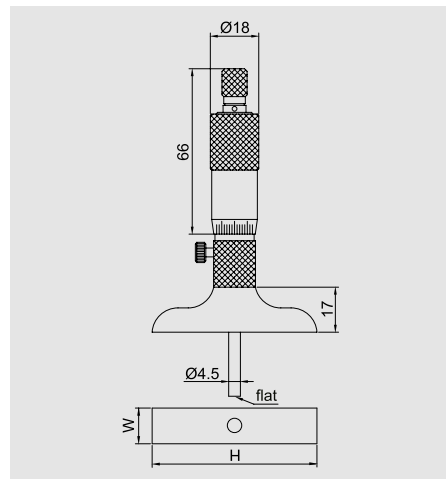

CARACTERÍSTICAS				PRECIO SIN IVA
Código	Rango	Base (HxW)	Vara	
391-001-01	0-25mm	101.5x17mm	1pc	\$70.00
391-006-01	0-150mm	101.5x17mm	6pcs	\$119.00
391-008-01	0-200mm	101.5x17mm	8pcs	\$177.00

MICROMETRO DE PROFUNDIDAD

Serie 392

Herramienta



Dibujo Técnico

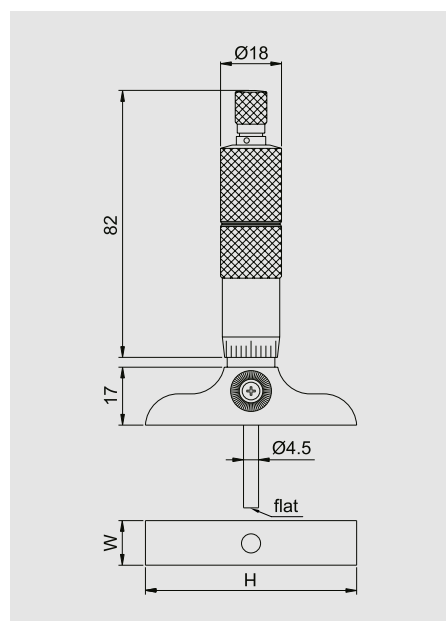

CARACTERÍSTICAS				PRECIO SIN IVA
Código	Rango	Base (HxW)	Vara	
392-002-01	0-50mm	101.5x17mm	2pcs	\$111.00

TERMOMETRO -700°

Serie IT700

Herramienta



© Copyright © Accud - No. 100-0001

TERMOMETRO



CARACTERÍSTICAS		PRECIO SIN IVA
Código	IT700	\$59.00
Rango de temperatura de medida	-50°C-950°C	
Exactitud	1.5 °C or 2%	
Repetibilidad	0.5°C or 1%	
Relación punto-distancia	12:1	
Tiempo de reacción	500ms	
Resolución	0.1 °C	
Fuente de alimentación	9Vbatería	
Emisividad	0.1-1.00 (ajustable)	
Peso	185g	
Dimensión	186x119x50 mm	

PORTA MICROMETRO

Serie 392

Herramienta



Dibujo Técnico

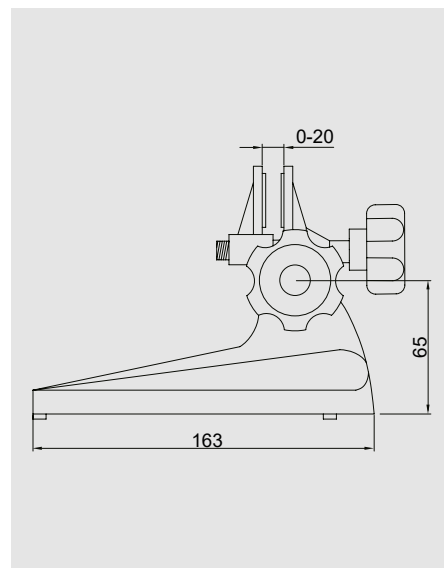

CARACTERÍSTICAS	PRECIO
Código	SIN IVA
381-000-00	\$17,00

MEDIDOR DE ESPESORES

Serie 392

Herramienta



Dibujo Técnico

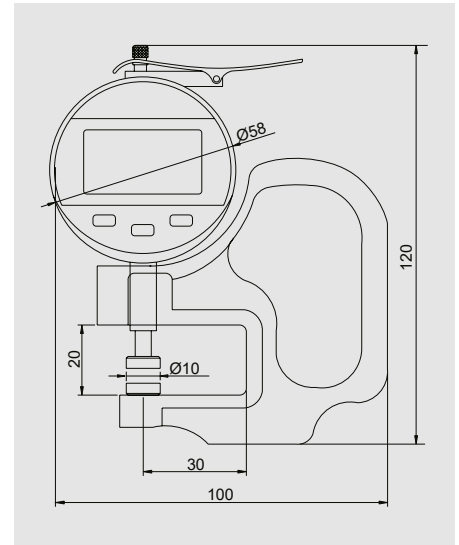

CARACTERÍSTICAS			PRECIO SIN IVA
Código	Sugerencias	L	
441-010-01	0-10mm/0-0.4"	0.005mm	\$204.00
441-010-11	0-10mm/0-0.4"	0.02mm	\$95.00

VARIOS

BLOQUE EN V MAGNETICO

Serie 634

Herramienta



Dibujo Técnico

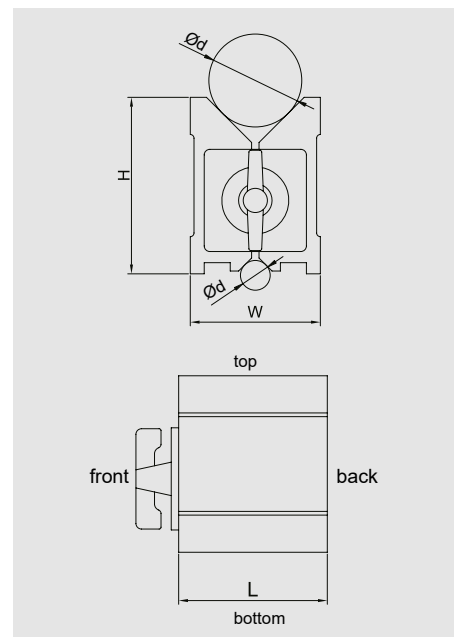

CARACTERÍSTICAS						PRECIO SIN IVA
Código	Tamaño (LxWxH)	Para shaftrange (Ød)	Fuerza magnética	Ranuras en V y escuadra trasera	Paralelismo superior e inferior	
634-067-01	80x70x95mm	6-67mm	64kgf	10µm	10µm	\$110.00

BLOQUE NIVEL

Serie 713

Herramienta



Dibujo Técnico

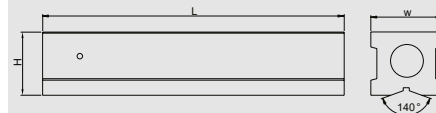

CARACTERÍSTICAS				PRECIO SIN IVA
Código	Talla (L)	H	W	
713-008-02	200mm	42	47	\$127.00

MEDIDOR DE RADIOS

Serie 942

Herramienta



Dibujo Técnico

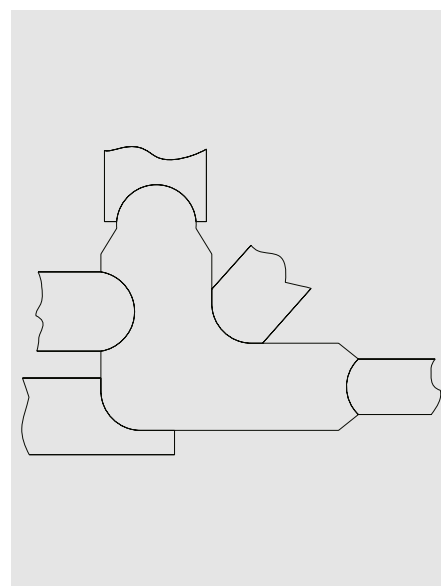

CARACTERÍSTICAS				PRECIO SIN IVA
Código	Rango	Cantidad	Radio incluido (mm)	
942-013-26	0.5 - 13mm	26	0.5, 1, 1.5, 2, 2.5, 3, 3.5, 4, 4.5, 5, 5.5, 6, 6.5, 7, 7.5, 8, 8.5, 9, 9.5, 10, 10.5, 11, 11.5, 12, 12.5, 13	\$37.00

JGO. DE MEDIDOR DE TELESCOPIO

Serie 951

Herramienta



Dibujo Técnico

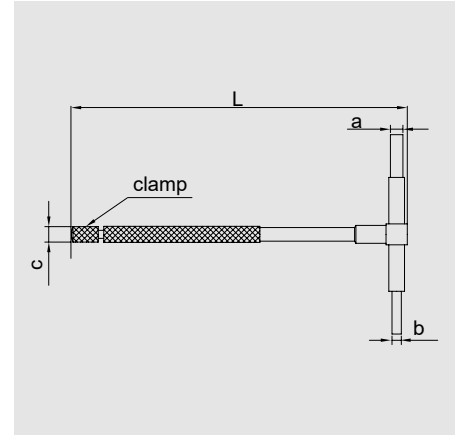

CARACTERÍSTICAS						PRECIO SIN IVA
Código	Cada gama de calibre	L	a	b	c	
951-006-01	8-12.7mm	115mm	Ø3.9mm	Ø2.9mm	Ø6.2mm	\$28.00
	12.7-19mm	115mm	Ø5.3mm	Ø3.8mm	Ø6.2mm	
	19-32mm	115mm	Ø5.3mm	Ø3.8mm	Ø6.2mm	
	32-54mm	137mm	Ø7.6mm	Ø6.1mm	Ø7.2mm	
	54-90mm	137mm	Ø7.6mm	Ø6.1mm	Ø7.2mm	
	90-150mm	137mm	Ø7.6mm	Ø6.1mm	Ø7.2mm	

COMPAS DE MUELLE INTERIOR

Serie 982

Herramienta



Dibujo Técnico

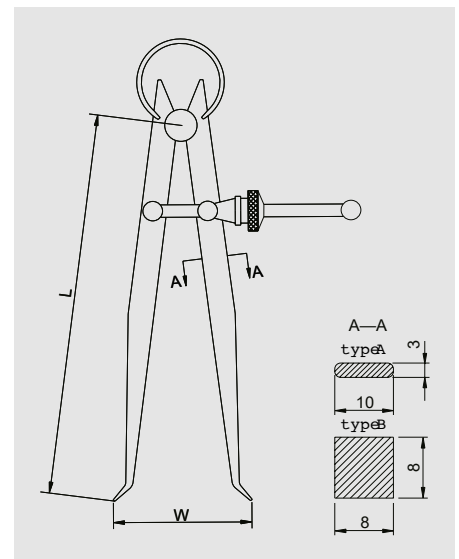

CARACTERÍSTICAS				PRECIO SIN IVA
Código	Talla(L)	Rango(W)	Tipo	
982-008-01	200mm	18 - 190mm	A	9.75
982-012-01	300mm	20 - 290mm	A	14.00

VARIOS

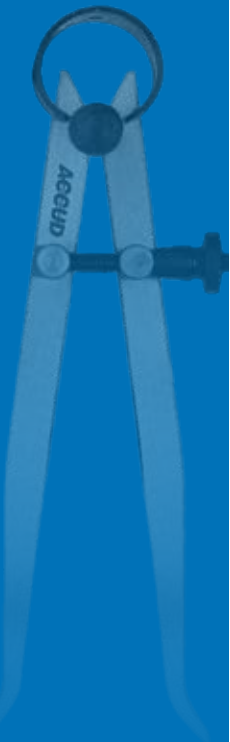

COMPAS DE MUELLE INTERIOR

Serie 985

Herramienta



Dibujo Técnico

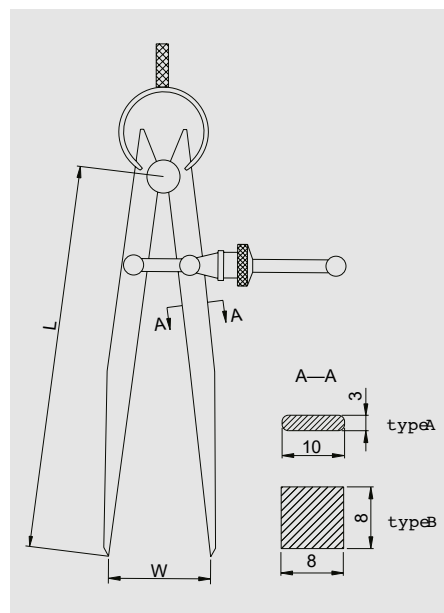

CARACTERÍSTICAS

Código	Talla(L)	Rango(W)	Tipo	PRECIO SIN IVA
985-008-01	200mm	0 - 190mm	A	\$9.75

PINZA INTERIOR

Serie 981

Herramienta



Dibujo Técnico

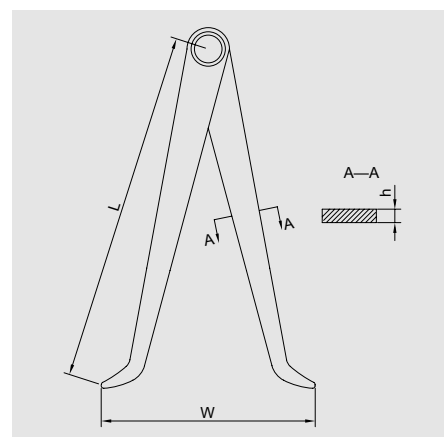

CARACTERÍSTICAS

Código	Talla(L)	Rango(W)	h	PRECIO SIN IVA
981-006-01	150mm	15 - 150mm	2mm	\$7.00
981-008-01	200mm	15 - 200mm	2mm	\$7.00
981-010-01	250mm	15 - 250mm	3mm	\$8.00
981-012-01	300mm	15 - 300mm	3mm	\$10.00

VARIOS



PINZA EXTERIORES

Serie 983

Herramienta



Dibujo Técnico

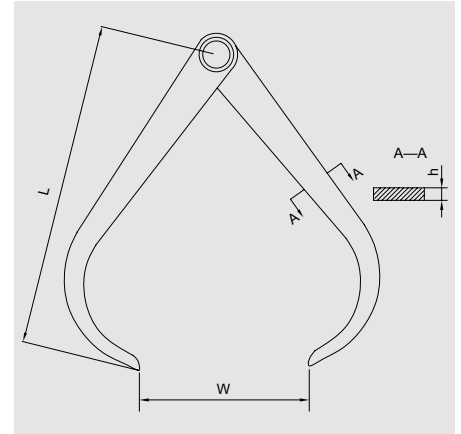

CARACTERÍSTICAS				PRECIO SIN IVA
Código	Talla(L)	Rango(W)	h	
983-006-01	150mm	0 - 150mm	2mm	\$7.00
983-008-01	200mm	0 - 200mm	2mm	\$7.00
983-010-01	250mm	0 - 250mm	3mm	\$8.00
983-012-01	300mm	0 - 300mm	3mm	\$10.00

TRAZADOR

Serie 981

Herramienta



Dibujo Técnico

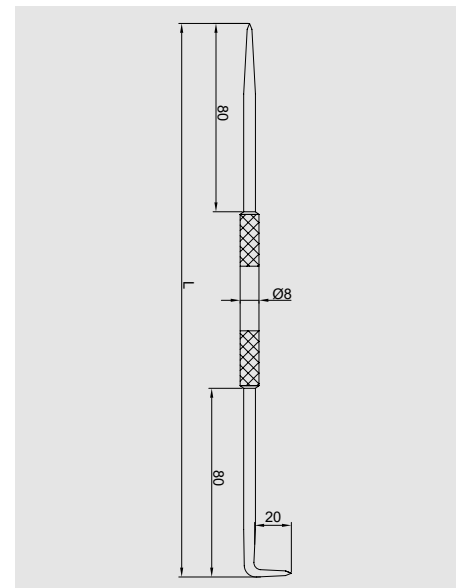

CARACTERÍSTICAS			PRECIO SIN IVA
Código	Sugerencias	L	
995-009-01	puntas templadas	235mm	\$4.50

BKB

MAQUINARIA INDUSTRIAL

CONTÁCTATE CON NUESTRAS ASESORAS



SANDRA QUISHPE

+593 99 162 0679
squishpe@bkbmaquinaria.com



KATHYA ESPINEL

+593 99 399 5925
kespinel@bkbmaquinaria.com

Dirección: Parque Delta
Pana Norte km 12 1/2 y el Arenal

Teléfono: 2 2 428 504 / 2 428 505
www.bkbmaquinaria.com

